

INSTRUCTIONS

OJ-DA-MODULE-2R250

Optional module with two 250VAC, 1A relays



670112 10/24 (UVN) © 2024 OJ Electronics A/S

OJ Drives®

A DRIVES PROGRAMME DEDICATED TO VENTILATION SOLUTIONS



Contents

1.	Product presentation	3
2.	Introduction	3
3.	Key to symbols.	3
4.	Ensuring safety before installation	3
5.	Product use	4
6.	Prohibition on use	4
7.	EMC – Electromagnetic compatibility	4
8.	Approvals and certifications.	4
9.	Product programme	5
10.	Mechanical installation.	5
11.	Electrical installation.	7
12.	Terminal and connector overview	7
13.	Checklist – mechanical and electrical installation	8
14.	Functions	8
15.	Maintenance.	8
16.	Troubleshooting	10
17.	Repair	10
18.	Disposal	10
19.	Technical specifications	10

1. Product presentation

OJ-DA-MODULE-2R250 is an add-on module for the OJ drive range of motor controllers. The OJ-DA-MODULE-2R250 contain two 250VAC/1A potential free relays. Product use: see section 5.

2. Introduction

- Read this manual thoroughly and follow the instructions it contains before taking the OJ-DA-MODULE-2R250 into use.
- This manual contains important information and should be used when installing, connecting and commissioning the OJ-DA-MODULE-2R250 as well as during maintenance, service and troubleshooting.
- If the instructions contained in this manual are not observed, the liability of the supplier and the warranty shall be voided (see also section 6. *Prohibition on use*).
- Technical descriptions, drawings and figures must not be wholly or partly copied or disclosed to third parties without the permission of OJ Electronics A/S.
- All rights are reserved if the product is included in patent rights or other form of registration.

3. Key to symbols

Particular attention should be paid to the sections in these instructions which are marked with symbols and warnings.



Warning

- This symbol is used where there is a risk of severe or fatal personal injury.



Caution

- This symbol is used where potentially dangerous situations may result in minor or moderate personal injury. The symbol is also used to warn against unsafe and hazardous conditions.



Note

- This symbol is used to indicate important information and in situations which may result in serious damage to equipment and property.



Warning

4. Ensuring safety before installation

- Disconnect the supply voltage to the OJ drive before you start to install the OJ-DA-MODULE-2R250.
- OJ drives contain capacitors which become charged during operation. These capacitors can remain charged even after the power supply has been cut off. There is a risk of severe personal injury if the connection terminals or wire ends are touched before these capacitors have been completely discharged. The discharge time is about 3 minutes under normal conditions.
- OJ-DA-MODULE-2R250 contains free and exposed electronic components. Electrostatic discharge (ESD) may destroy the product. To prevent destruction of the product's electronic components, the OJ-DA-MODULE-2R250 must be handled and installed correctly with respect to electrostatic discharge (ESD).
- OJ-DA-MODULE-2R250 must only be installed by qualified personnel or people who have received appropriate training and have thus become qualified to install the product.
- Qualified personnel are familiar with the instructions and safety precautions described in this manual.
- Mains voltage must always be disconnected before any service or maintenance tasks are performed on the product.
- After installing the OJ-DA-MODULE-2R250, check that all openings, covers and cable glands are correctly fitted and closed before connecting the OJ drive to mains voltage. Unused cable glands must be replaced with blank glands.

5. Product use

- The OJ-DA-MODULE-2R250 should be used when one or two 250VAC/1A potential free relays are required.



Warning

6. Prohibition on use

- The OJ-DA-MODULE-2R250 must not be taken into use until the machine or product into which it is incorporated has in its entirety been declared to be in conformity with all relevant national and international regulations.
- The product carries a manufacturer's warranty if installed in accordance with these instructions and applicable installation regulations.
- If the product has been damaged, e.g. during transport, it must not be used.

7. EMC – Electromagnetic compatibility

- No special conditions.

8. Approvals and certifications

CE marking

- OJ Electronics A/S hereby declares under sole responsibility that the product complies with the following European Parliament directives:
- LVD – Low voltage : 2014/35/E
- EMC – Electromagnetic compatibility : 2014/30/EU
- RoHS – Hazardous substances: 2011/65/EU and amendment annex II: EU/2015/863

UK marking

- OJ electronics Ltd hereby declares under sole responsibility that the product complies with the following UK legislations:
- LVD – The Electrical Equipment (Safty) Regulations 2016
- EMC – The Electromagnetic Compatibility Regulations 2016
- Ecodesign – The Ecodesign for Energy-Related products and Energy Information Regulations 2010 as retained in UK law and amended.
- RoHS – The Restriction of the use of Certain Hazardous Substances in Electrical and Electronic Equipment Regulations 2012

Product standard

- In accordance with EN/BS 61800-2 – Adjustable speed electrical power drive systems. Part 2. General requirements.

EMC – Electromagnetic compatibility

- The OJ DV has built-in EMC filter.

Safety

- In accordance with EN/BS 61800-5-1

RoHS compatible

- Contains no hazardous substances according to the RoHS Directive.

9. Product programme

The OJ-DA-MODULE-2R250 product programme consists of: See table 9.

Table 9	
Functions	OJ-DA-MODULE-2R250
Relay output; max. 250V/1A	2

Product label

- OJ-DA-MODULE-2R250 is equipped with a label containing a production code.

10. Mechanical installation



Warning

Incorrect mechanical installation may cause faulty operation and impaired performance.

- OJ-DA-MODULE-2R250 must only be installed by trained/qualified personnel.
- When opening the OJ drive, disconnect the voltage supply to the OJ drive and wait approx. 3 minutes before opening the cover.
- Open the OJ drive by loosening the six Torx 20 screws in its plastic cover.
- Carefully remove the loosened cover.
- OJ-DA-MODULE-2R250 should be fitted in the space between the input terminals and the motor output terminals.
- Fit the OJ-DA-MODULE-2R250 by gently inserting the circuit board at an angle into the 3-point holder in the space between the input terminals and the motor output terminals. H1&H3: see fig. 10.1; H4&H5: see fig. 10.2.

Fig. 10.1

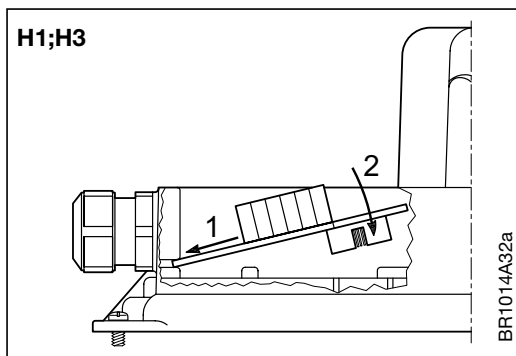
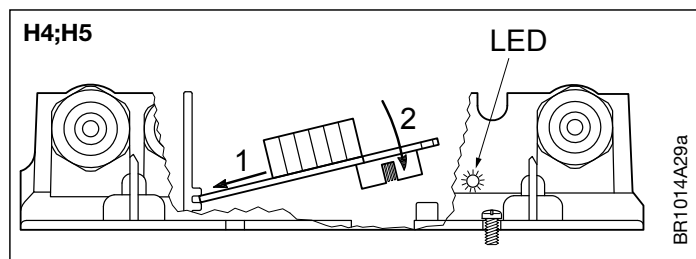

Fig. 10.2





Note

- In OJ drive sizes 0.55 kW....3.0 kW, the 3-point holder is located on the bottom – see fig. 10.3.
- In OJ drive sizes 4.0 kW....15.0 kW, the 3-point holder is located on the left-hand side – see fig. 10.4.
- Carefully align the 10-pin connectors opposite one another and gently press them together – H1&H3: see fig. 10.5; H4&H5: see fig. 10.6.
- Attach the OJ-DA-MODULE-2R250 with the accompanying screw – H1&H3: see fig. 10.7; H4&H5: see fig. 10.8.

Fig. 10.3

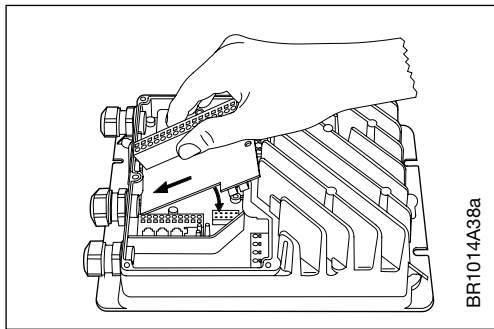

Fig. 10.4

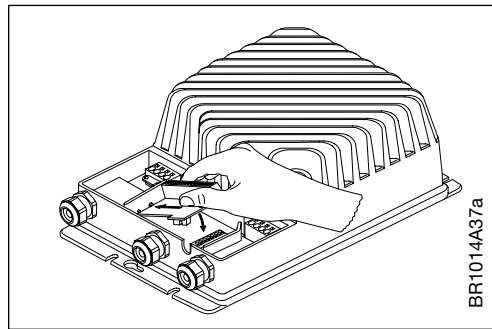

Fig. 10.5

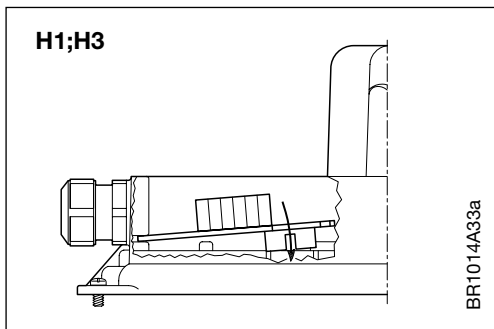

Fig. 10.6

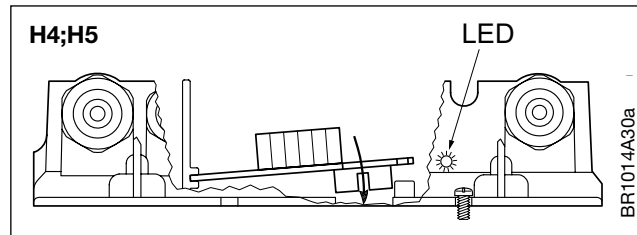

Fig. 10.7

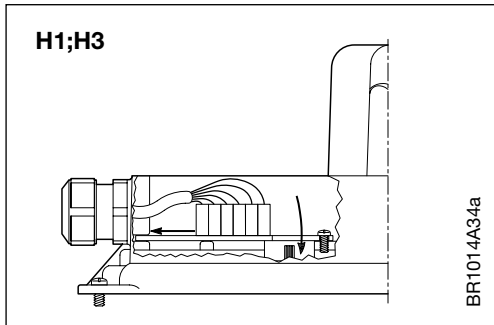
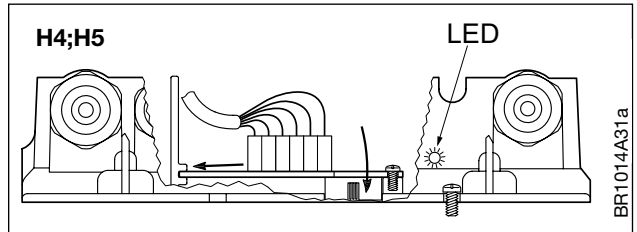

Fig. 10.8



Cable entries – cable glands – strain relief

- Insert signal cables for the OJ-DA-MODULE-2R250 into the OJ drive through the cable glands.
- The OJ drive is factory-equipped with three cable glands. If additional cable entries are required, remove the knockout from the middle of the OJ drive and fit an M20 cable gland.
- The OJ drive is not equipped with threads for cable glands, the additional cable glands must be attached by means of a separate M20 nut on the inside.
- Remember to re-tighten the cable glands to ensure the ingress protection level of the OJ drive and to provide cable strain relief.

11. Electrical installation



Warning

- The OJ-DA-MODULE-2R250 must only be electrically installed by trained/qualified personnel.

Spring terminals

- The connection terminals are spring loaded and the stripped wire can be easily inserted into the terminal by carefully pushing the wire into the terminal without using tools. Alternatively, the terminal spring can be loosened by pressing it lightly with a screwdriver or similar implement. See fig. 11.
- Solid and multi-core cables/leads can be used.
- If multi-core cables/leads are used, core sleeves/ end sleeves must always be used.
- Stripped wire ends or end sleeves must be between 8 and 15 mm.
- Wires can be removed by carefully loosening the terminal spring by pressing lightly with a screwdriver or similar implement. See fig. 11.

Fig. 11

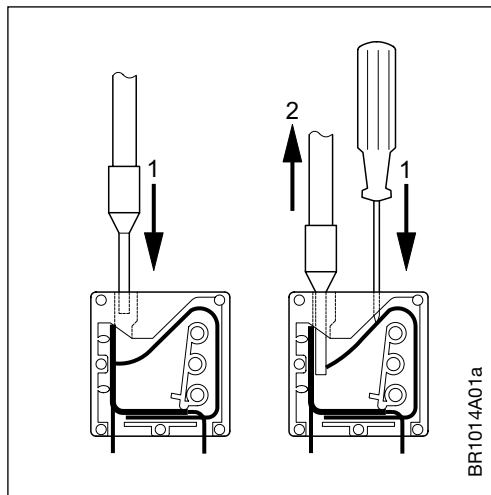

BR101-4A01a

12. Terminal and connector overview

Fig. 12

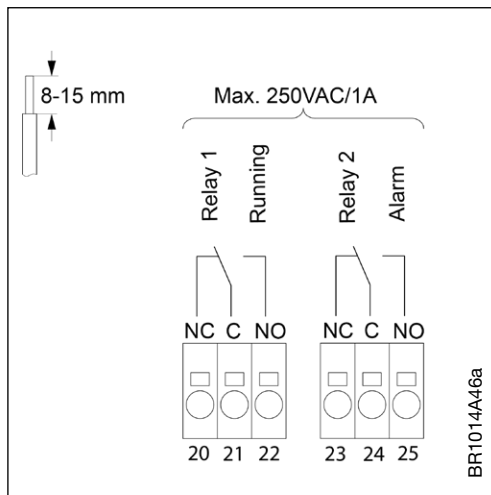

BR101-4A46a

13. Checklist – mechanical and electrical installation

- Before the OJ drive is energized for the first time, installation and connection must be checked.
- Use the table below as a checklist.

Item to be checked	Description of check	✓
Completion	Check that the entire installation is ready to be commissioned, both electrically and mechanically, before energizing the installation.	
	Check that no people or animals are present in the vicinity of moving parts.	
Product conformity	Check that the voltage on the wires connected to the OJ-DA-MODULE-2R250 does not exceed 250VAC/1A	
Mechanical installation	Check that the OJ-DA-MODULE-2R250 has been attached correctly, that the connector between the OJ-DA-MODULE-2R250 and the OJ drive has been fitted properly and that the OJ-DA-MODULE-2R250 has been secured with the accompanying screw.	
	Check that the OJ drive terminal cover has been correctly fitted and that all screws have been tightened before energizing the product.	
	Check that all unused cable glands and other unused openings are appropriately blanked off in accordance with the applicable enclosure rating.	
Electrical installation	Check that cables have been correctly inserted into the OJ drive and that the cable glands have been correctly tightened.	
	Pull the signal leads gently to ensure that they have been correctly inserted and properly connected to the terminals of the OJ-DA-MODULE-2R250.	
	Check that all cables are correctly ended and securely attached.	
	Check that all cables are free of visible damage throughout their length.	
	Check whether there are any loose connections, which may cause overheating and serious damage to the product and property.	
Cabling	Check that all cabling has been fitted correctly and that motor and control cables are kept apart in separate cable conduits.	
	Check that all cables are securely attached and relieved of tension and torsion.	

14. Functions

Relay output 1: Operating signal

- Relay 1 (terminals 20, 21, 22) can be used to send an operating signal to an external device. See fig. 12.
- The signal output is a changeover relay which is closed between terminals 20 and 21 in idle position and otherwise closes between terminals 21 and 22.
- When the OJ drive receives a start/release signal, the relay changes position, closing between terminals 21 and 22. The relay is simultaneously opened between terminals 21 and 20.
- When the start/release signal to the OJ drive is removed, the relay returns to its starting position, closing between terminals 20 and 21.

Relay output 2: Alarm relay

- Relay 2 (terminals 23, 24, 25) can be used to send an alarm signal to an external device. See fig. 12.
- When the OJ drive powers up, the relay changes position, closing between terminals 24 and 25.
- If the OJ drive has stopped due to a critical alarm, the relay will switch position and close between terminals 23 and 24. The relay is simultaneously opened between terminals 24 and 25.
- When the alarm is reset/acknowledged, the relay returns to its original position, closing between terminals 24 and 25.

15. Maintenance

- Under normal operating conditions and load profiles, OJ-DA-MODULE-2R250 is maintenance free.

16. Troubleshooting



Warning

- Before opening The OJ drive, the mains voltage must be disconnected for at least 3 minutes to ensure there is no risk of dangerous residual currents in electronic circuits or capacitors.
- If natural drafts through the duct system cause the fan to rotate even though it has received no operating signal, there is a risk that the motor will induce voltage on the OJ drive motor terminals, making them dangerous to touch.
- Troubleshooting overview

Symptom	Cause	Action
OJ-DA-MODULE-2R250 inoperative	Lacking supply voltage to the OJ drive	Check the voltage supply to the OJ drive terminals "L" and "N" on 230V models (H1). "L1", "L2" and "L3" on 3x400V and 3x230V models (H3...H5). (Nominal supply voltage is stated on the rating plate.)
		Check whether short-circuit protection has been activated.
	Poor electrical connections	Check that the voltage supply to the OJ drive has not been cut off by other components.
		Check electrical connections on OJ drive and OJ-DA-MODULE-2R250. Check that the 10-pin connector between the OJ-DA-MODULE-2R250 and OJ drive has been properly fitted and connected.
Defective OJ drive controller	Replace the OJ drive. Never attempt to repair a defective OJ drive controller. Contact your supplier for replacement/repair.	
Defective OJ-DA-MODULE-2R250	Replace OJ-DA-MODULE-2R250.	

17. Repair



Warning

- OJ-DA-MODULE-2R250 cannot be repaired on site. Never attempt to repair a defective unit.
- Contact your supplier to obtain a replacement.
- Additional technical data are available on request from OJ Electronics A/S.

18. Disposal



- OJ-DA-MODULE-2R250 contains electronic components which must not be disposed of together with household waste.
- OJ-DA-MODULE-2R250 must be disposed of in accordance with applicable local rules and regulations.
- OJ-DA-MODULE-2R250 meets the requirements on marking of electronic waste contained in the European WEEE Directive 2012/19/EU.

19. Technical specifications

Technical data

Electrical connection	6 spring terminals, max. 2.5 mm ²
Digital relay outputs	.2 potential-free changeover relays, max. 1A, 250VAC
Ambient operating temperature	-40/+50°C
Ambient temperature, storage	-50/+70°C
Dimensions	80.5 x 59.5 x 27 mm
Enclosure	IP00
Weight	44 g