

OJ Drives®

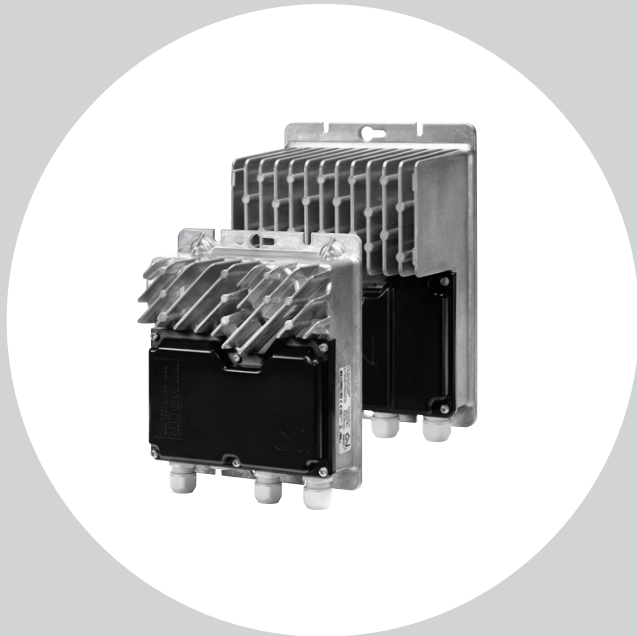

OJ DV GEN II

- 0.5 - 1.3 kW / 0.7 -1.7 Hp
- 208 - 277 V single phase supply
- IM, PMSM, PMSynRM motor
- Ignition-protected
- CE, UL, CSA

OJ DV GEN II series

OJ DV GEN II is the upgraded version of our successful series of dedicated drives for ventilation applications.

This new version is fully backwards compatible with the same power variants, which hold the exact mechanical dimensions and comes with the same Modbus and BACnet protocols.

This new generation of drives offers excellent possibilities for customization.

Design

The OJ DV Gen II offers a flexible installation design – they can be mounted inside or outside the airflow.

OJ DV GEN II is suitable for any system, as it can be configured specifically for your application. Adding option modules and mounting a cooling fan on the OJ DV GEN II enlarge the application use.

Moreover, the OJ DV GEN II series has been extended and can now be provided with a local user interface.

The OJ DV GEN II removable front cover design allows easy access to the connection compartment and provides sufficient space for connecting the option module cables. The OJ DV GEN II front cover facilitates safe mounting on the aluminium frame, securing the desired sealing grade.

Controlling

The OJ DV GEN II can be controlled using a 0-10V or a 4-20mA signal and through Modbus RTU or BACnet MS/TP. In addition, the digital input and output interfaces can be used to determine and configure the control method.

Grid immunity

The OJ DV GEN II offers Over Voltage Detection, allowing the drives to survive in most types of grids worldwide. Our drives are robust and handle grid disturbances, such as notches, spikes and transients.

Built-in EMC filter

The OJ DV GEN II series comes with a fully integrated EMC filter and therefore meets the emissions and immunity norms for industrial and residential areas according to EN 61800-3 (C1 and C2) and FCC §47 part 15 B. and ICES-003.

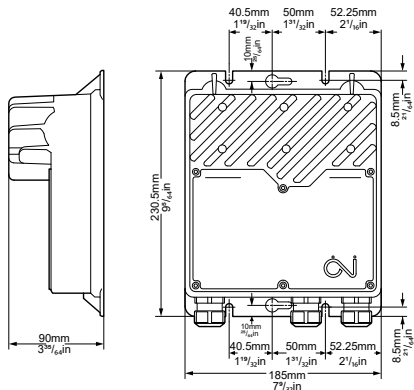

BR1014A53A

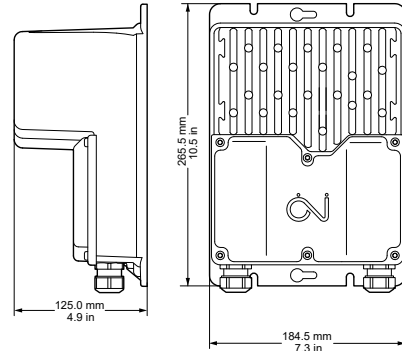

BR1014A59A

Dimensions H1

Dimensions H1x

	Type	DV-1005	DV-1007	DV-1011	DV-2011	DV-1013
Frame size		H1				H1x
Power size	kW	0.5	0.75	1.1	1.1	1.3
Horsepower	Hp	0.7	1.0	1.5	1.5	1.7
Efficiency	%	> 94%				
Power supply						
Voltage	VAC	1 x 208-240 VAC 50/60 Hz +/-10%			1 x 208-277 VAC 50/60 Hz +/-10%	1 x 240 VAC 50/60 Hz +/-10%
Supply current at max. load at nominal supply voltage (208V / 240V)	A	3.6 / 3.1	5.4 / 4.7	7.9 / 6.8	7.9 / 5.9	9.3 / 8.1
Power factor (cos-phi) at max. load		> 0.99 (Active PFC)				
Motor output						
Nominal motor power (on shaft) *1	kW	0.5	0.8	1.15	1.15	1.3
Frequency	Hz	AC motor: 0-120 PM motor: 0-595				
Max. output voltage	Vrms	3 x 0 - 250 VAC				
Max. output current	Arms	2	3.2	4.5	4.5	5.2
Protection						
Max. fuse	A	16				
Short circuit capacity	A	5000				
Motor output		Short-circuit protected between phases				
Motor		Protected by current limit				
Over-voltage protection		Yes, <400V (NTC)				
Overload protection		Current and temperature overload protection				
Environment						
Operating temperature	°C/°F	-40°C to +50°C / -40°F to +122°F				
Storage temperature	°C/°F	-40°C to +70°C / -40°F to +158°F				
Protection rating		IP 54 & 65 / NEMA 4x				
Enclosure material		Aluminium				
Front cover		Plastic (Black front cover is UV resistant)				
Weight	kg/lbs	2.0 kg / 4.4 lbs				3.6 kg / 7.94 lbs
Humidity	% rh	10-95% rh, non-condensing				
Surface		Corrosion resistant according to EN/ISO 9223 Class 4				
Air flow / cooling		Turbulent air speed of min. 3 m/s or 9.84ft/s to achieve max. output power at max. ambient temperature. Turbulent air speed below 3m/s or 9.84ft/s and higher ambient temperature might lead to reduced output power: (3m/s or 9.84ft/s turbulent air speed is equivalent to 6.5m/s or 21.32ft/s laminar air speed)				
Interfaces						
Field bus		Modbus RTU , BACnet MS/TP				
Analogue Inputs		1 input 0-10 VDC 4-20mA PWM				
Analogue Output		1 output +10 VDC or +24 VDC				
Digital Inputs		2 inputs Internal pull-up to +24VDC				
Digital Output		1 output Open collector, Internal pullup to +10 VDC or +24 VDC				
Status LED		Green/yellow/red				
Features						
Technology		Sinusoidal back-EMF signal controlled via FOC (Field Oriented Control)				
Software updating		Yes, via serial interface				
Motor parameters		Preprogrammed by OJ or on-site configuration				
Short-circuit protection		Yes				
Integrated EMC filters		Yes				
Approvals						
EMC		EN/BS 61800-3 (C1 & C2) / FCC §47 part 15 B. and ICES-003				
LVD		EN/BS 61800-5-1 / UL 61800-5-1				
Product standard		IEC/BS 61800 Part 2				
North America *2		UL -61800-5-1 / CS22.2 No. 274				
Ignition-protected components		IEC/UL60335-2-40, cl.22.116 & cl.22.117 / UL 121201 Class1, Div2				
Overvoltage category		III				
Pollution degree		2				
Altitude		1000 m / 3280 ft: Without derating and 2000 m / 6560 ft: With 1% derating per 100 meter/328 ft. above 1000 meter / 3280 ft.				
Supply earthing system		TN / TT / IT				
RoHS Directive		Yes				
Product approvals						
Note: Data are valid at: nominal supply voltage, +25°C or +77°F and sufficient air flow *1: Motor Power Factor = 0.8 and efficiency = 90% *2: Only available with black front cover						

HVAC-3-04-26-OJ-DV-GEN-II-208-277V-GB - Subject to alterations · © The OJ trademark is a registered trademark belonging to OJ Electronics A/S

OJ cannot be held liable for any errors in the material. OJ reserves the right to alter its products without notice. This also applies to products already on order, provided that such alterations can be made without requiring subsequent changes in specifications already agreed. The contents of this material may be subject to copyright and other intellectual property rights and is either the property of or used under license by OJ Electronics. The OJ trademark is a registered trademark of OJ Electronics.