

OJ Drives®



OJ DV GEN II with Local User Interface

- 2.4 - 15 kW / 3.2 - 20.0 Hp
- 460 - 600 V three phase supply
- IM, PMSM, PMSynRM motor
- Ignition-protected
- 2" color touchscreen
- UL, CSA
- Ambient temperature up to +70°C/+158°F

OJ DV GEN II series

OJ DV GEN II is the upgraded version of our series of dedicated drives for ventilation applications. GEN II drives are fully backwards compatible with the corresponding power variants, which have the exact same mechanical dimensions and the same Modbus and BACnet protocols. GEN II drives offer excellent possibilities for customization.

Design

The flexible installation design lets you mount the drive inside or outside the airflow. OJ DV GEN II is suitable for any system, as it can be configured specifically for your application. Adding option modules and mounting a cooling fan on the OJ DV GEN II further expands the drives' potential.

The OJ DV GEN II removable front cover design allows easy access to the connection compartment and ample space for connecting the option module cables. The cover also facilitates safe mounting on the aluminum frame, ensuring the desired sealing grade.

Local User Interface

The built-in 2" touchscreen with color display lets users carry out basic set-up and local operation. The intuitive interface also gives access to readouts of a wide range of information. All this facilitates easy troubleshooting and swift responses to alarms.

Control

The OJ DV GEN II can be controlled using a 0–10 V or a 4–20 mA signal and through Modbus RTU or BACnet MS/TP. In addition, the digital input and output interfaces can be used to configure the control method.

Grid immunity

Over Voltage Detection enables these robust drives to cope with most types of grids worldwide, handling disturbances such as notches, spikes and transients.

Built-in EMC filter

The OJ DV GEN II series comes with a fully integrated EMC filter, meeting the emissions and immunity norms for industrial and residential areas according to EN 61800-3 (C1 and C2) and FCC §47 part 15 B. and ICES-003.

	Type	DV-6024-xxLx	DV-6030-xxLx	DV-6040-xxLx	DV-6055-xxLx	DV-6075-xxLx	DV-6110-xxLx	DV-6150-xxLx	
Frame size		H4				H5			
Power size	kW	2.4	3.0	4.0	5.5	7.5	11	15	
Horsepower	Hp	3.2	4.0	5.5	7.5	10.0	15.0	20.0	
Efficiency	%	> 96.5%				> 97.5%			
Power supply									
Voltage	V AC	3 x 460 - 600 V AC 50/60 Hz +/-10%							
Supply current at max. load at nominal supply voltage (460 V/600 V) @+50°C/+122°F	A	4.0	5.0	6.8	9.3	11.5	23.0	27.0	
Supply current at max. load at nominal supply voltage (460 V/600 V) @+60°C/+140°F *5	A	4.0	5.0	6.8	9.3	11.5 *3	18.5	27.0	
Supply current at max. load at nominal supply voltage (460 V/600 V) @+65°C/+149°F *5	A	4.0	4.0	6.8	9.3	-	18.5	-	
Supply current at max. load at nominal supply voltage (460 V/600 V) @+70°C/+158°F *5	A	3.1	-	6.8	9.3	-	16.2	-	
Power factor (cos-phi) at max. load		> 0.9							
Motor output									
Nominal motor power (on shaft) *1	kW	2.4	3.0	4.0	5.5	7.5	11	15	
Frequency	Hz	AC motor: 0-120 PM motor: 0-595							
Max. output voltage	Vrms	3 x 0 - 0.9 x Vin							
Max. output current @+50°C/+122°F	Arms	4.9	6.3	8.3	10.5	18.3	23.5	28.0	
Max. output current @+60°C/+140°F *5	Arms	4.9	6.3	8.3	10.5	18.3 *3	23.5	28.0 *3	
Max. output current @+65°C/+149°F *5	Arms	4.9	6.0	8.3	10.5	-	21.0	-	
Max. output current @+70°C/+158°F *5	Arms	4.9	-	8.3	10.5	-	19.7	21	
Protection									
Max. fuse	A	16				32			
Short circuit capacity	A	5000							
Motor output		Short-circuit protected between phases and phase to earth, Thermal Memory Retention							
Motor		Protected by current limit							
Max over-voltage		<700 V							
Overload protection		Current and temperature overload protection							
Environment									
Operating temperature	°C/°F	-40°C to +50°C / -40°F to +122°F (Up to +70°C / +158°F depending on variant, see above)							
Storage temperature	°C/°F	-40°C to +70°C / -40°F to +158°F							
Protection rating		IP 54 & 65 / NEMA 4x							
Enclosure material		Aluminium							
Front cover		PBT PP (Black front cover is UV resistant)							
Weight	kg/lbs	3.0 kg / 6.6 lbs			3.9 kg / 8.6 lbs		9.5 kg / 20.9 lbs		
Humidity	% rh	10-95% rh, non-condensing							
Surface		Corrosion resistant according to EN/ISO 9223 Class 4							
Air flow / cooling		Turbulent air speed of min. 3 m/s or 9.84 ft/s to achieve max. output power at max. ambient temperature. Turbulent air speed below 3 m/s or 9.84 ft/s and higher ambient temperature might lead to reduced output power. (3 m/s or 9.84 ft/s turbulent air speed is equivalent to 6.5 m/s or 21.32 ft/s laminar air speed)							
Interfaces									
Field bus		Modbus RTU , BACnet MS/TP							
Analogue Inputs		1 input: 0-10 V DC or 4-20mA or PWM							
Analogue Output		1 output: +10 V DC or +24 V DC							
Digital Inputs		2 inputs: Internal pull-up to +24 V DC							
Digital Output		1 output: Open collector, Internal pullup to +10 V DC or +24 V DC							
Status LED		Green/yellow/red							
User Interface		2 inch color resistive touch							
Features									
Technology		Sinusoidal back-EMF signal controlled via FOC (Field Oriented Control)							
Software updating		Yes, via serial interface							
Motor parameters		Preprogrammed by OJ or on-site configuration							
Short-circuit protection		Yes							
Integrated EMC filters		Yes, C1 and C2							
Approvals									
EMC		FCC §47 part 15 B. and ICES-003							
Safety		UL 61800-5-1 CS22.2 No. 274							
Product standard		IEC 61800 Part 2							
Ignition-protected components		IEC/UL60335-2-40, cl.22.116 & cl.22.117 / UL 121201 Class1, Div2 *4							
Overvoltage category		III							
Pollution degree		2							
Altitude		1.000 m / 3.280 ft: Without derating and 2.000 m / 6.560 ft: With 1% derating per 100 meter/328 ft. above 1000 meter / 3280 ft.							
Supply earthing system		TN / TT							
Product approvals									
Note: Data are valid at: nominal supply voltage, +25°C or +77°F and sufficient air flow *1: Motor Power Factor = 0.8 and efficiency = 90% * 2: H5 OGF variant is limited to 32A *3: Reduced when with cooling fan *4: Max. +50°C/+122°F ambient temp. *5: Special part number									

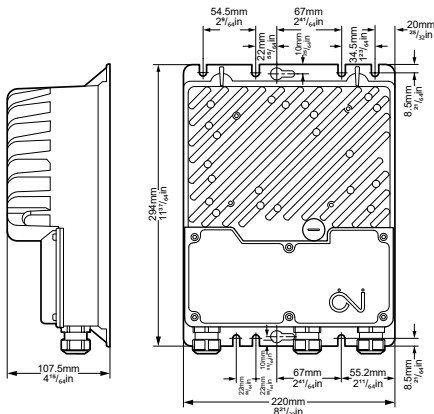

BR1014A52b

Dimensions H4

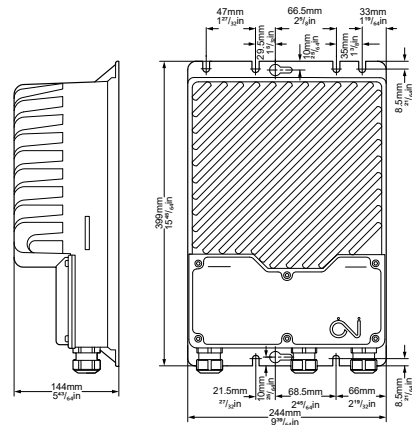

BR1014A50a

Dimensions H5

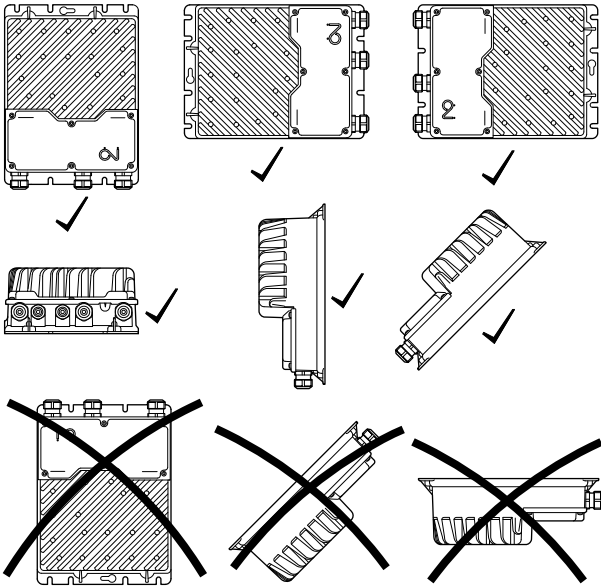

BR1014A55a

Correct mounting

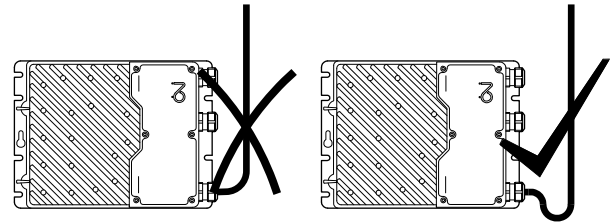

BR1014A56a

Correct mounting